

Cal. VC10E

15.55 mm
[12H --- 6H]

13.00 mm
[3H --- 9H]

H 2.38 mm

Item	Version No.
Specification	Version 2
Appearance	Version 4
Casing	Version 6
Hand Fitting	Version 5
Hand Setting Stem	Version 5
Dial - 1	Version 4
Casing Ring	Version 2
Assembly Plan	Version 4
Hands	Version 3



MOVEMENT SPECIFICATIONS

CAL.VC10E 5 1/2 Ligne Quartz Movement Two Hands

1. MOVEMENT DIMENSIONS

- Outside diameter ϕ 15.55mm (12H~6H) x 13.0mm (3H~9H)
- Casing diameter ϕ 15.15mm (12H~6H)
- Total height 2.38 mm (including the battery)

2. TIME STANDARD

- Type of quartz oscillator Tuning fork
- Frequency of quartz oscillator 32,768 H Z
- Accuracy Monthly rate: Less than 20 seconds per month at normal temperature range
- Regulation device Nil
- Regulation hands unbalance Minute : Less than 0.40 μ N·m (40.0mg·mm)
Hour : Less than 0.60 μ N·m (60.0mg·mm)

3. BATTERY

- Type Silver oxide battery
- Size ϕ 5.8 x t 2.1 (mm)
- Battery life Approx. 2 years
- Recommended battery SR521SW (SEIZAIKEN)

4. STEPPING MOTOR

- Type Two pole stepping motor
- Step 180° every second

5. JEWEL

0 jewel

6. ANTIMAGNETISM

(direct current magnetic field)

\geq 1600 A / m

7. SHOCK RESISTANCE

On equal level with general quartz movement

8. OPERATING TEMPERATURE RANGE

From - 5°C to + 50°C

9. SETTING MECHANISM

- Crown at normal position Free
- Crown pulled out to 1st click Time setting, second setting and reset switch

10. TEST OF ACCURACY

- Equipment to be used Quartz Tester QT - 99
Greiner Quartz Timer - C
Witschi Q-Tester 4000
- Duration of measurement 10 seconds
- Microphone to be used Electromagnetic detection type (DM-1)

11. ATTACHED PARTS

Parts Name	Parts Code
Silver oxide battery	3016 - 1410
Hand setting stem	0351-1730 (Regular) / 0351-1200 (Long)
Hour wheel	0271 - 2980
Dial washer	0491 - 0130

*** All specifications are subject to change without notice.**

Crystal oscillator

Battery

Battery side holding spring

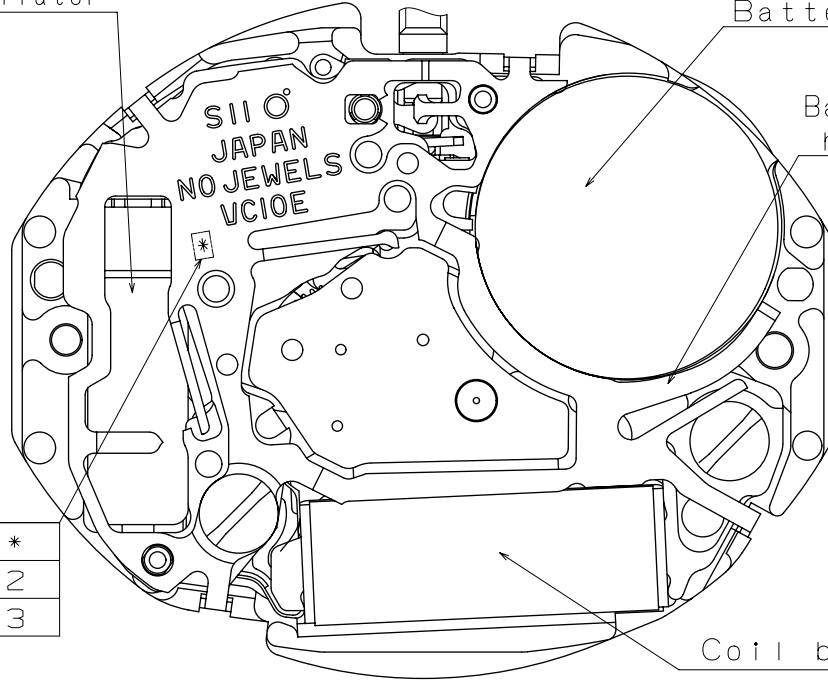

	*
TYPE M	2
TYPE L	3

Coil block

Dial leg hole

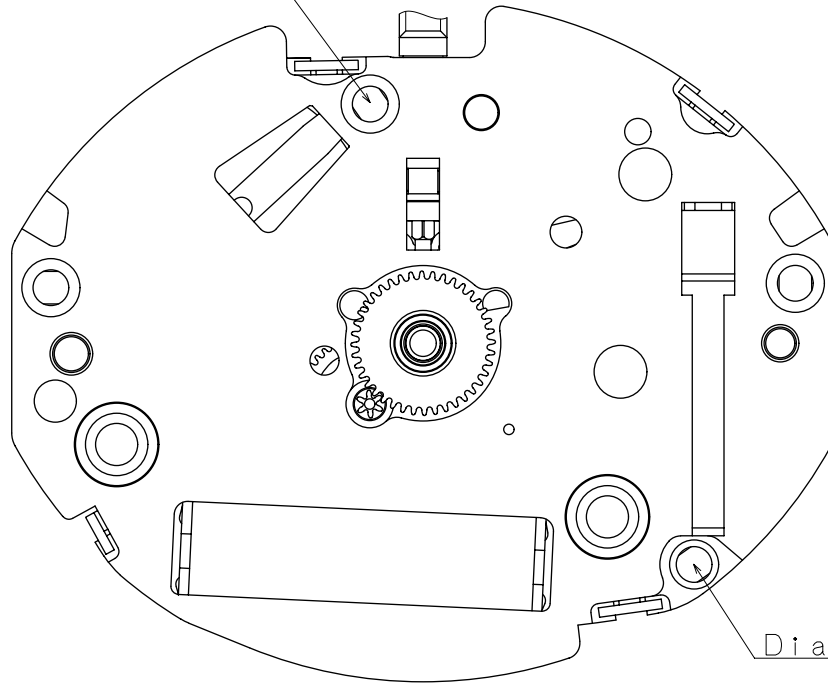

Dial leg hole

Scale : 7/1
Unit : 1=1/100mm

Version:4

Casing

Cal. VC10E

Battery Side holding spring Type. * Pull out stroke 40

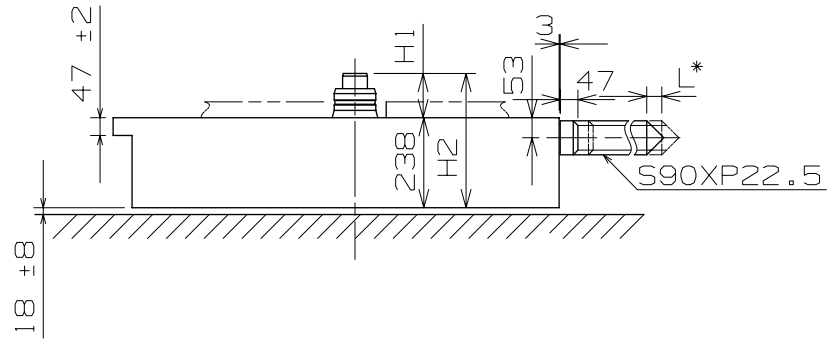

Center post 中心柱位		TYPE M 一般針高	TYPE L 高針
Maximum height from main plate surface. 與機芯平面之最大高度	H1	117	150
Total height incl. movement. 機芯總高度	H2	355	388

Hand Setting Stem	TYPE A	TYPE B
L1	1648	2140

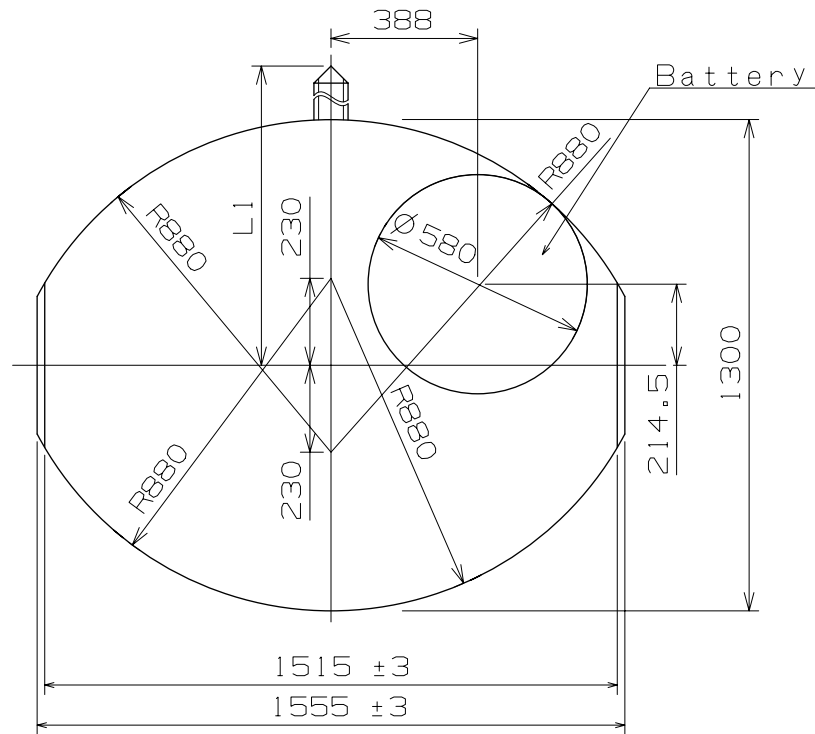

Scale : 5/1
Unit : 1=1/100mm

Version:6

Hand fitting

Cal. VC10E

Hour hand unbalance $\leq 0.6 \mu\text{N}\cdot\text{m}$ (60mg·mm)
 Minute hand unbalance $\leq 0.4 \mu\text{N}\cdot\text{m}$ (40mg·mm)

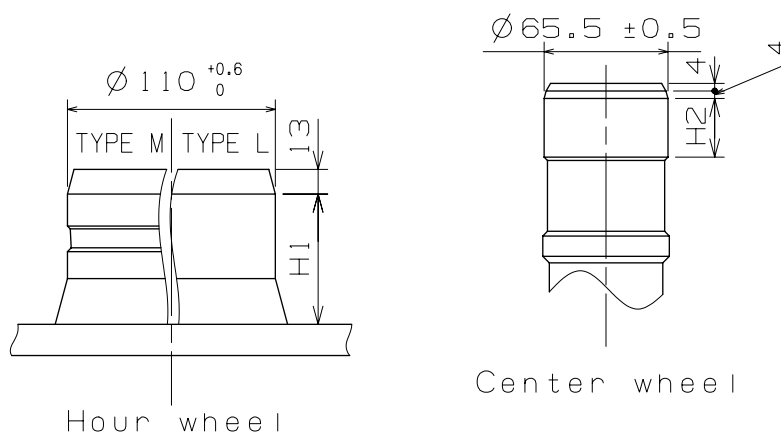

	Part. No.		Dimension	
	Hour wheel	Center wheel	H1	H2
TYPE M	0271 2980	0270 0820	69	31
TYPE L	0271 3040	0270 0830	99	56

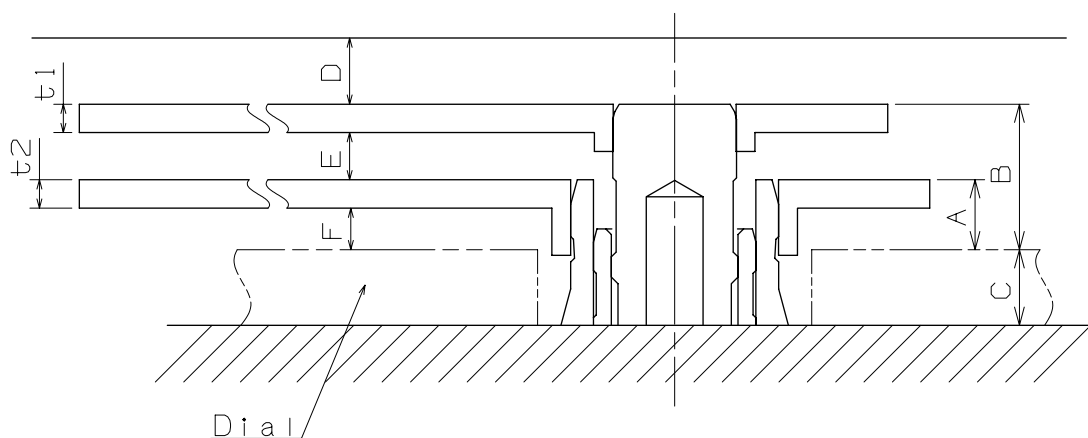

	A	B	C	D	E	F	t1	t2
TYPE M	37	77	40	35	25	22	15	15
TYPE L	35	78	72	35	28	20	15	15

Scale : 25/1

Version:5

Unit : 1=1/100mm

Hand fitting

Cal. VC10E

Hour hand unbalance $\leq 0.6 \mu\text{N}\cdot\text{m}$ (60mg·mm)
 Minute hand unbalance $\leq 0.4 \mu\text{N}\cdot\text{m}$ (40mg·mm)

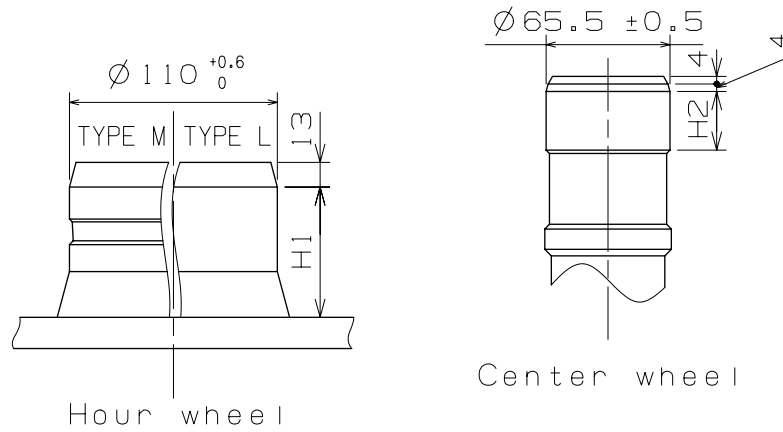

	Part. No.		Dimension	
	Hour wheel 時針輪	Center wheel 分針輪	H1	H2
TYPE M 一般針高	0271 2980	0270 0820	69	31
TYPE L 高針	0271 3040	0270 0830	99	56

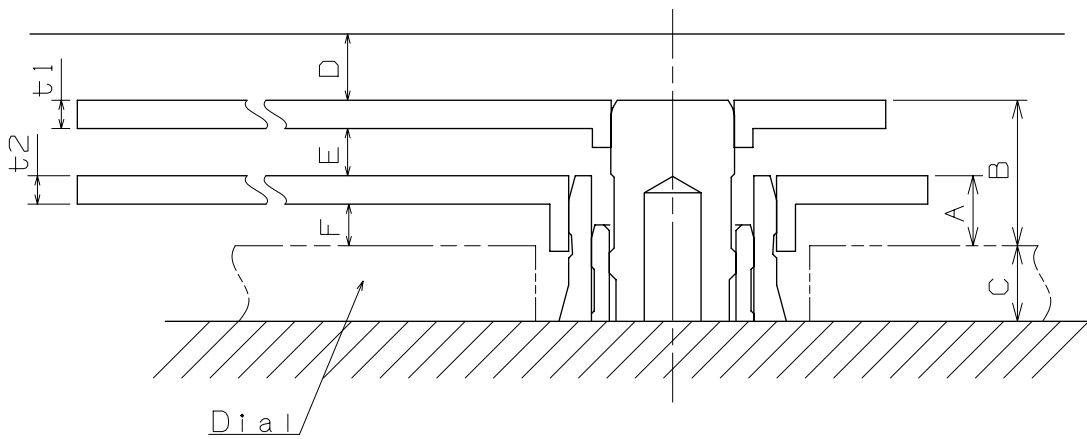

	A	B	C	D	E	F	t1	t2
TYPE M 一般針高	37	77	40	35	25	22	15	15
TYPE L 高針	35	78	72	35	28	20	15	15

Scale : 25/1

Unit : 1=1/100mm

Version:5

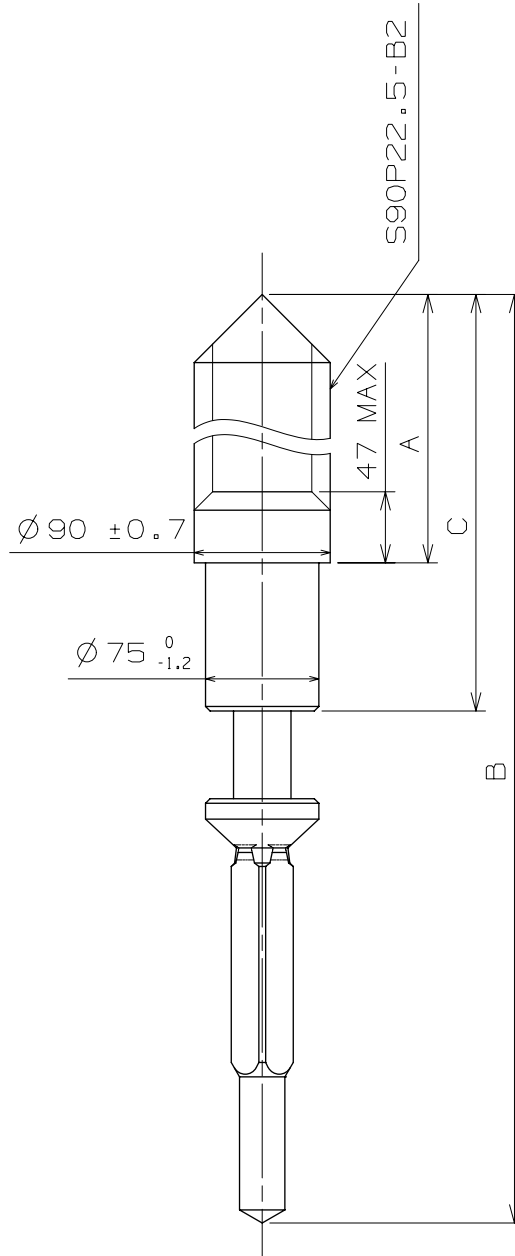

	Part.No.	A	B	C
TYPE A	0351 1730	1105	1542	1203
TYPE B	0351 1200	1597	2034	1695

Scale : 20/1

Version:5

Unit : 1=1/100mm

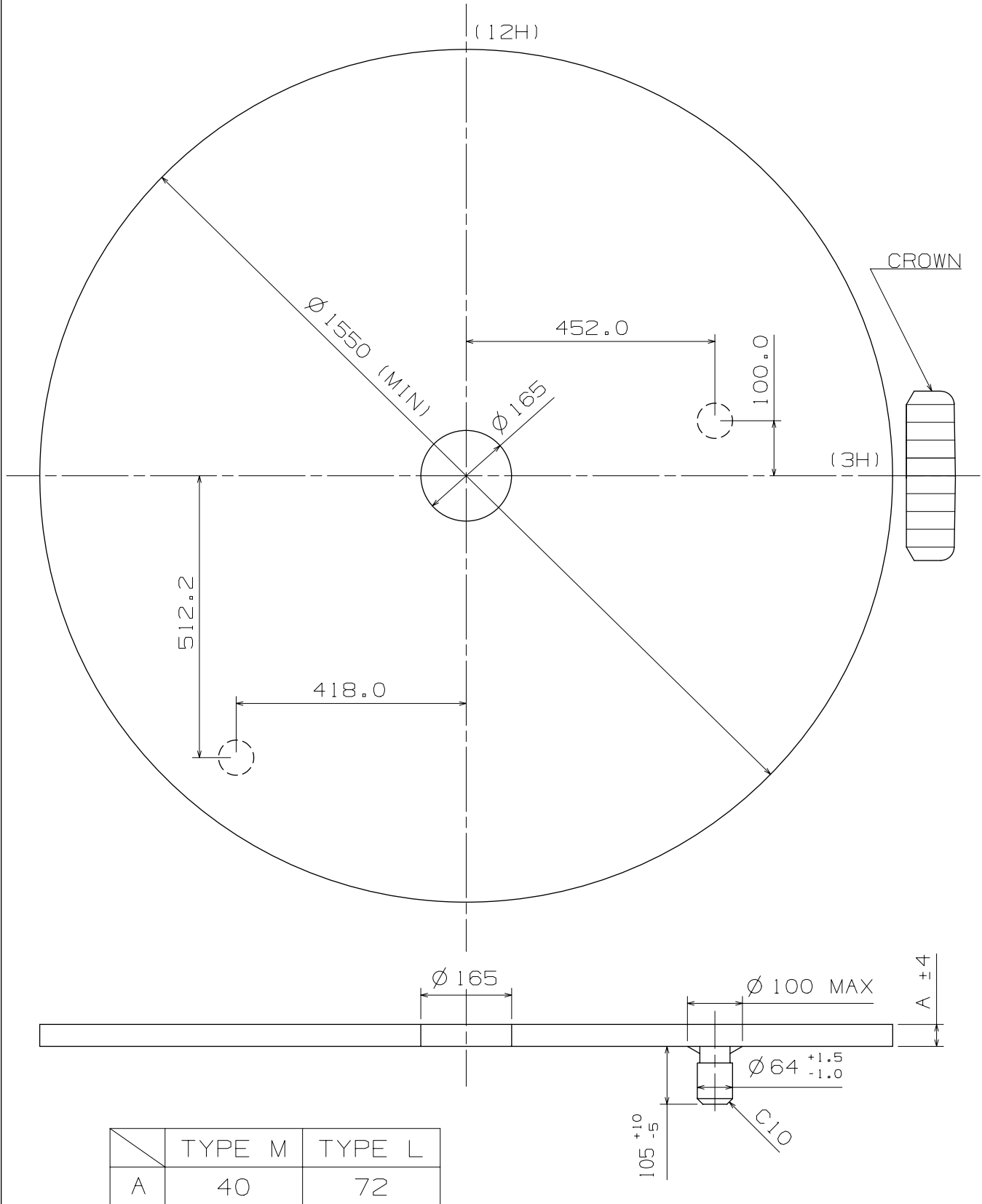

	TYPE M	TYPE L
A	40	72

Scale : 10/1
Unit : 1=1/100

Version:4

Casing Ring

Cal. VC10E

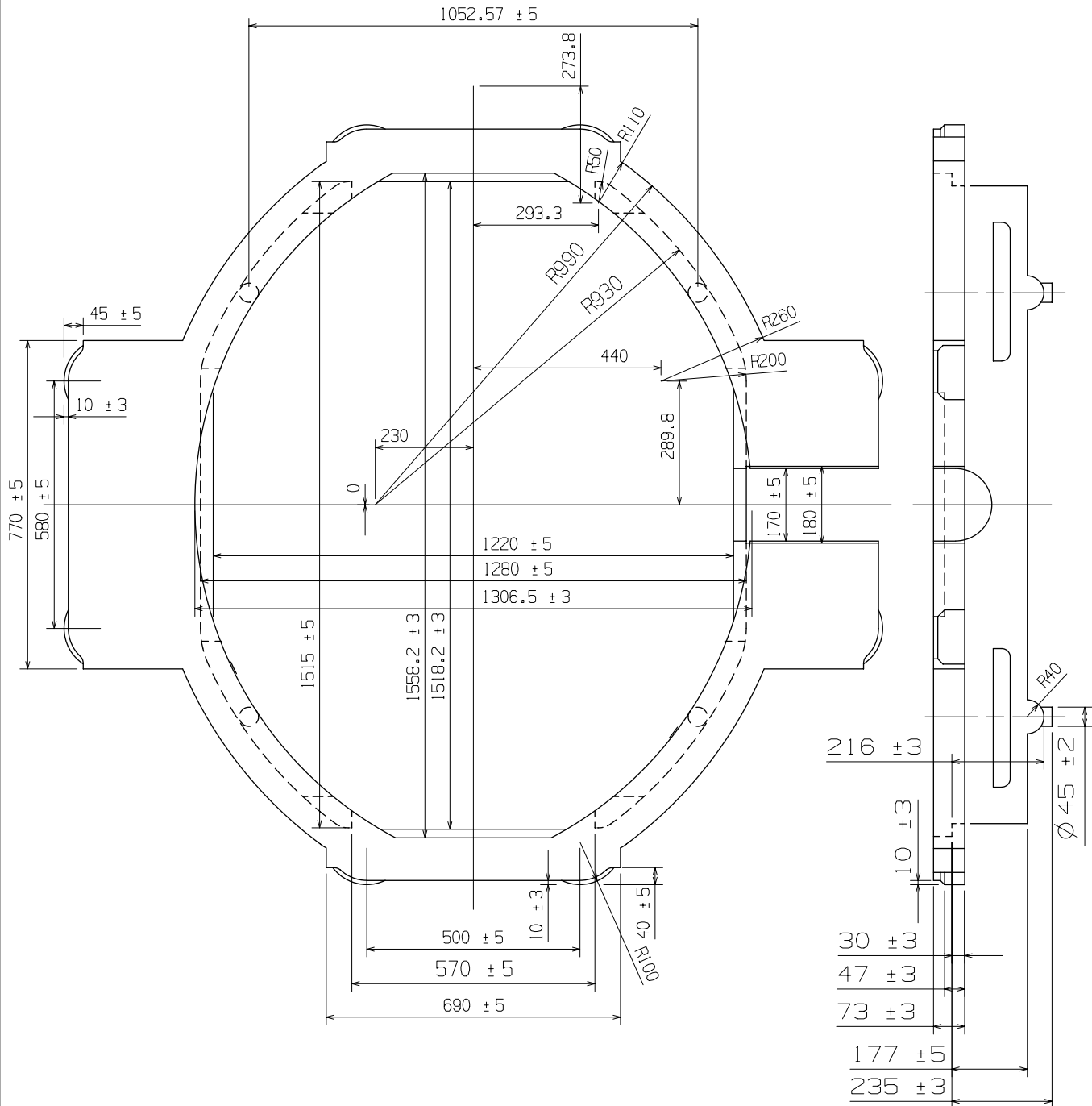

Scale : 7/1
Unit : 1=1/100

Version:2

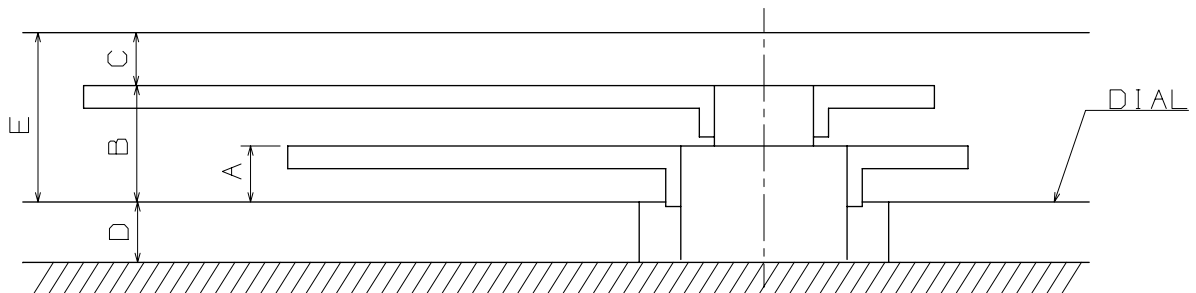
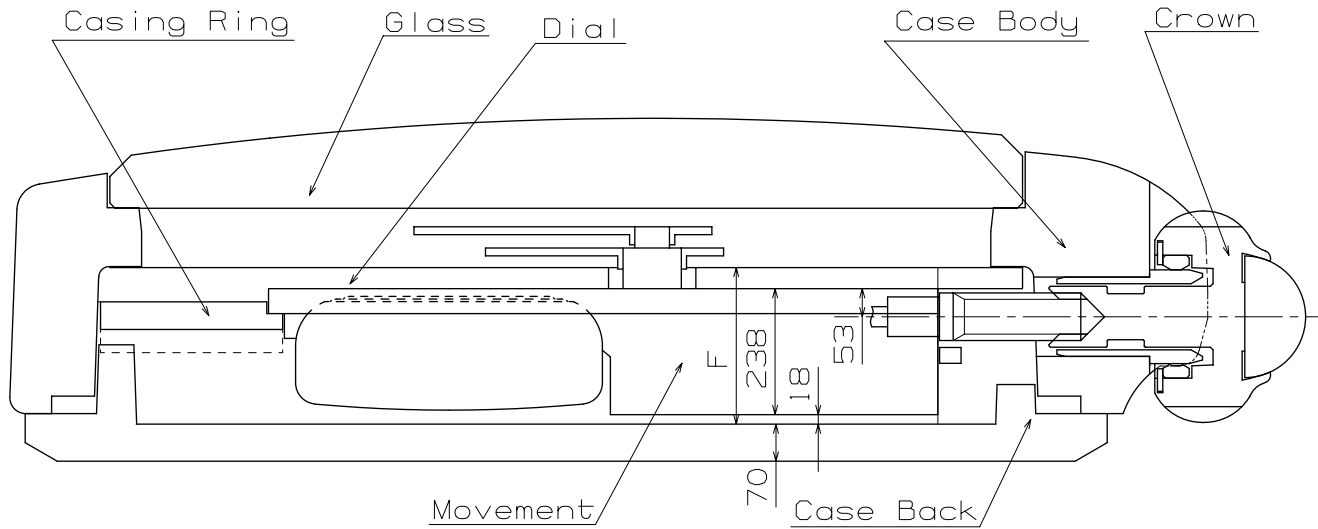

	A	B	C	D	E	F
TYPE M	37	77	35	40	112	296
TYPE L	35	78	35	72	113	328

Scale : -
Unit : 1=1/100

Version:4

Hands

Cal. VC10E

MINUTE

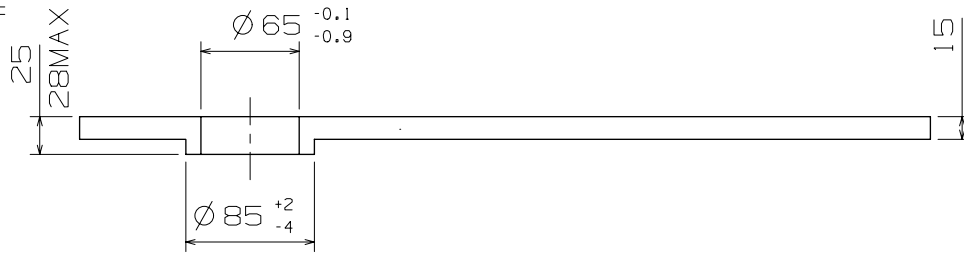

HOUR

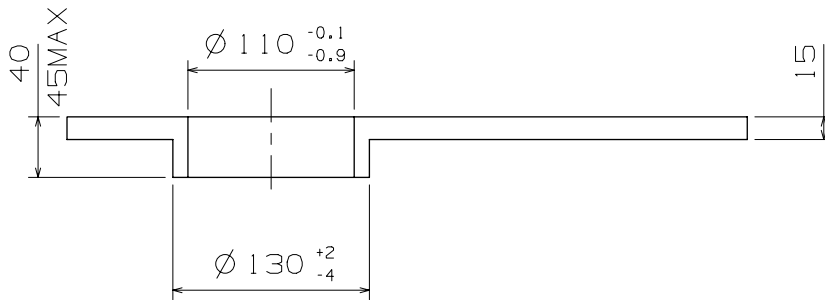

Scale : -

Unit : 1=1/100

Version:3